

CORDOLI E ACCESSORI

CURVA 12

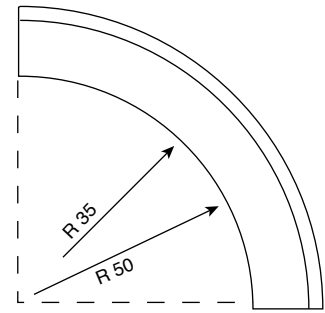
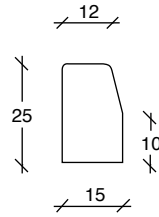
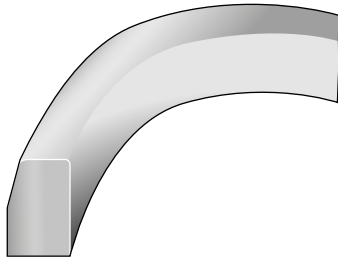

CODICE	DESCRIZIONE	DIMENSIONE in cm.	LUNGHEZZA in cm.	PESO in Kg.	IMBALLO nr. x pacco	NOTE
C0058	CURVA R. 35	12/15 x H.25	55	57	18	-
C0058.5	CURVA R. 50	12/15 x H.25	78	70	18	-

CORDOLO CON FERITOIA 12

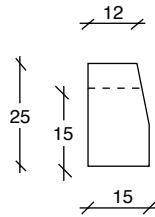
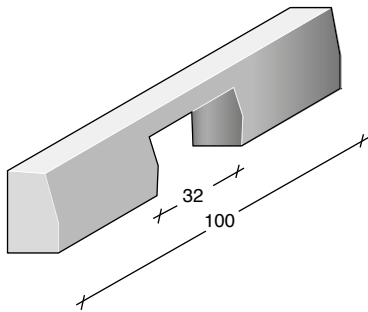

CODICE	DESCRIZIONE	DIMENSIONE in cm.	LUNGHEZZA in cm.	PESO in Kg.	IMBALLO nr. x pacco	NOTE
C0056	CORDOLO C/FERITOIA	12/15 x H.25	100	63	SFUSO	-

CORDOLO SMUSSO 12

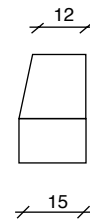
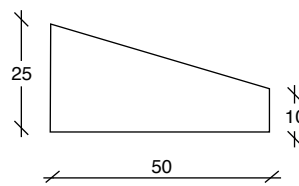
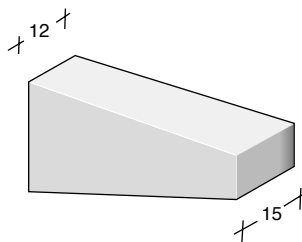

CODICE	DESCRIZIONE	DIMENSIONE in cm.	LUNGHEZZA in cm.	PESO in Kg.	IMBALLO nr. x pacco	NOTE
C0057.1	A SMUSSO DX-SX	12/15 x H.25	50	25	SFUSO	-

VOCE CAPITOLATO: Realizzazione di bordure laterali per tratti rettilinei e curvi, tramite cordolo prefabbricato in calcestruzzo vibrocompreso conforme alla norma UNI EN 1340, spessore in testa cm.... alla base cm. ... altezza cm. ... con bordo smussato o arrotondato nello spigolo a vista, in elementi di lunghezza cm., escluso stuccature in malta di cemento e massetto di fondazione. I cordoli dovranno essere prodotti e controllati, nelle varie fasi della produzione, da aziende in possesso di certificazione di Sistema Aziendale UNI EN ISO 9001:2015.



bosetti srl

B.3



25077 Roè Volciano BS

Tel. 0365 55.65.09

info@bosettisrl.it

www.bosettisrl.it